

POWER DISTRIBUTION UNIT (PDU)

USER GUIDE

The PDU is a combination unit with the 230V protection devices, 12Vdc control PCB, 12V protection devices (fuses) and the power supply in one box

PDU LAYOUT

Power Supply

The power supply can be accessed through a removable hatch at the top of the PDU but should only be done by a competent person and only when the leisure vehicle is disconnected from the mains supply.

12Vdc Fuses

The value of the 12Vdc fuses differ from model to model but are Identified by labels located above (fuse size) and below (circuit identification) the row of fuses.

MCB's

The number and value of the MCB's differ from model to model but are identified by a label located below the breakers.

RCD

The RCD is a 25A 30mA version.

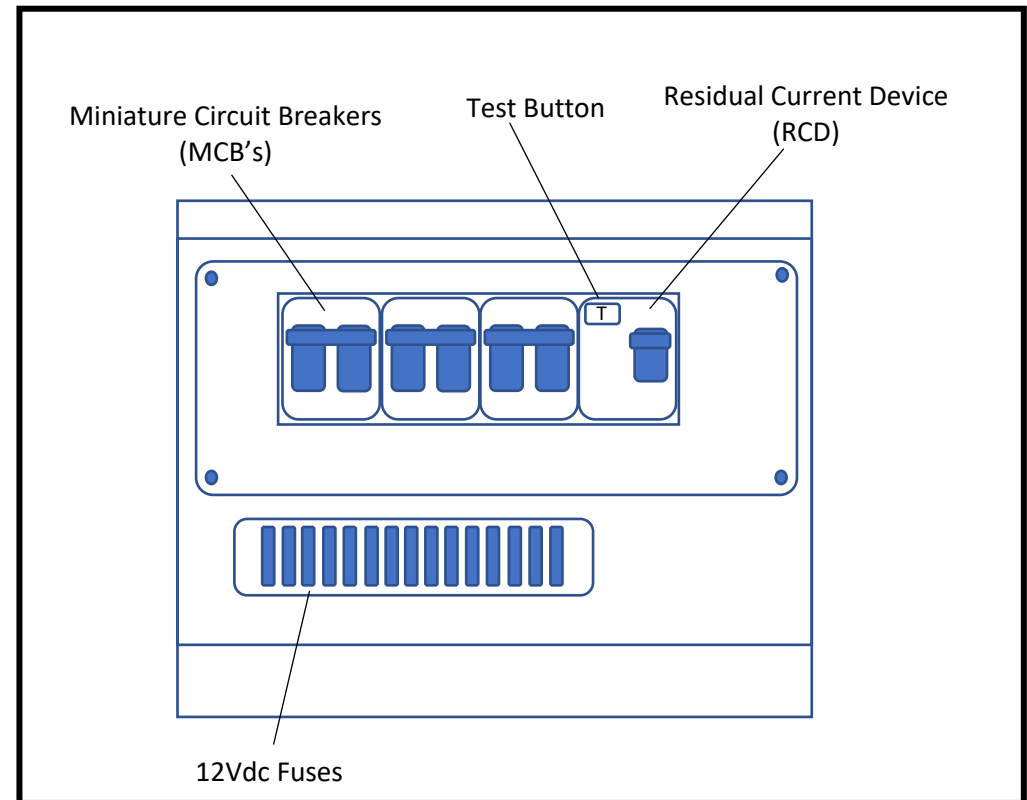

Connecting the Leisure Vehicle to the Mains Supply

- Always disconnect the electrical connector between the towing vehicle and the caravan before connecting an LV supply to the caravan and before charging the caravan battery by any other means.
- Check the suitability of the mains supply and that it meets the relevant standards, if unsure check with the site warden.
- Visually check the hook up cable for damage, if the cable is damaged DO NOT USE.
- Connect the hook up cable to the leisure vehicle before connecting to the mains supply, ensuring the cable is fully uncoiled to prevent heat build-up on the cable.
- Check the RCD by ensuring the latch is in the on position and by pressing the “TEST” button, the RCD should turn off, if it fails to do so contact your dealer or a competent person.
- Ensure the MCB’s are in the “ON” position, if the MCB’s fail to latch contact your dealer or a competent person.
- If using a generator, it must be started and stopped “off load”, which means disconnected from the leisure vehicle.
- Do not attempt to start a motor home engine whilst still connected to the mains supply.

Operating the PDU

The 12V system is designed to be controlled by a compatible control panel or by automatic operations, for the control panel instructions go to the control panel section of the hand book.

When the leisure vehicle is connected to a tow vehicle (engine off) the master switched circuits are powered by the tow vehicle, when the engine is running all the master switched circuits are automatically switched off to comply with EMC regulations, also the fridge (if 12V is selected) and leisure battery are now being powered/charged from the tow vehicle.

Note: when connected to the tow vehicle ensure the mains hook up cable has been disconnected.

Replacing 12Vdc fuses

NEVER replace a fuse with a higher rated than stated, doing so can risk damage to the wiring and void any warranty, if the fuse continues to blow contact your dealer or a competent person.

ALL ELECTRICAL WORK MUST BE CARRIED OUT BY A COMPETENT PERSON

